

Technical data | TQA - series

- 4-gear full metal gear
- Brushless PowerDrive motor with 30% higher efficiency
- Lithium-ion rechargeable battery with SafetyCell Technology
- Drive and electronics are completely dust-protected
- High speeds for precise and quick screwing
- Automatic lock
- Electronic torque setting
- Visual and acoustic signal when reaching a defined battery charge
- Support of high-strength aluminium
- The rapid charger ensures the battery is fully charged in less than 30 minutes

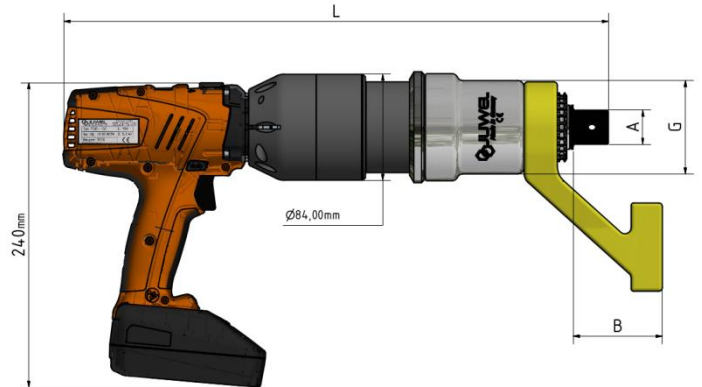

Typ		TQA-065	TQA-095	TQA-130	TQA-220	TQA-300	TQA - 400
Art.- Nummer / Art. No.		62 006 065	62 006 095	62 006 130	62 006 220	62 006 300	62 006 400
Leistungsbereich / torque range		50 - 650 Nm	100 - 950 Nm	100 - 1.300 Nm	100 - 2.200 Nm	100 - 3.000 Nm	150 - 4.000Nm
Drehzahl / speed	1 Gang / gear	8 U/min	7,7 U/min	4,25 U/min	2,1 U/min	1,2 U/min	1,25 U/min
Drehzahl / speed	2 Gang / gear	16 U/min	15 U/min	8,5 U/min	4,2 U/min	2,5 U/min	2,5 U/min
Drehzahl / speed	3 Gang / gear	36 U/min	35 U/min	20 U/min	9,5 U/min	6 U/min	5,5 U/min
Drehzahl / speed	4 Gang / gear	70 U/min	66 U/min	39 U/min	18 U/min	12 U/min	11 U/min
Länge / length mm		420	430	430	450	450	475
Ø Getriebe / gearbox mm	G	75	75	88	88	88	99
Werkzeugantrieb / square drive	A	3/4"	3/4" - 1"	1"	1"	1"	1 1/2"
Weite (mm) / Width	B	55/75	55/75	75	75	75	95
Gewicht / weight		4,75 kg	6,8kg	6,9 kg	8,2 kg	8,3 kg	9,5 kg

Technische Änderungen vorbehalten / Subject to technical changes